

THE MATERIALS AND INFORMATION CONTAINED IN THESE DOCUMENTS ARE THE SOLE PROPERTY OF SAF-T-CART. ANY DESIGN OR PRINCIPLE CONTAINED IN THE PRINTS IS CONSIDERED CONFIDENTIAL. THIS INFORMATION IS SUMMITTED TO YOU WITH AGREEMENT THAT IS IT NOT TO BE REPRODUCED, COPIED OR RELEASED IN PART OR IN WHOLE TO ANY COMPANY OR INDIVIDUAL. BY ACCEPTING THIS DOCUMENT YOU ARE AGREEING TO THE STATEMENTS ABOVE.

DIMENSIONS ARE IN INCHES UNLESS SPECIFIED OTHERWISE DO NOT TAKE DIMENSIONS FROM DRAWING
TOLERANCES
FRACTIONS ± 1/16"
ANGLES ± 0.5°
X.XX ± N/A
X.XXX ± N/A

DRAWN	COURTNEY HAYS	2/1/2024
CHECKED	REID WALKER/BILLY MONFORT	
QA/CWI	HARVEY STURDIVANT	
MFG	JARED STURDIVANT	
APPROVED	JIMMY WALKER	
ALL STRUCTURAL MEMBERS ARE ASTM A-36 CARBON STEEL U.N.O.		
ALL FILLET WELDS ARE 5/16" U.N.O.		



CLARKSDALE, MS 38614
800-542-2278
<http://www.saftcart.com/>
DETAILED MANUFACTURING PLANS

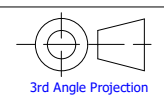

SIZE	MATERIAL	DWG NO	REV
B	VARIES	STP-16-FR	
SCALE	VARIES	SHEET 1 OF 2	

STP-16-FR

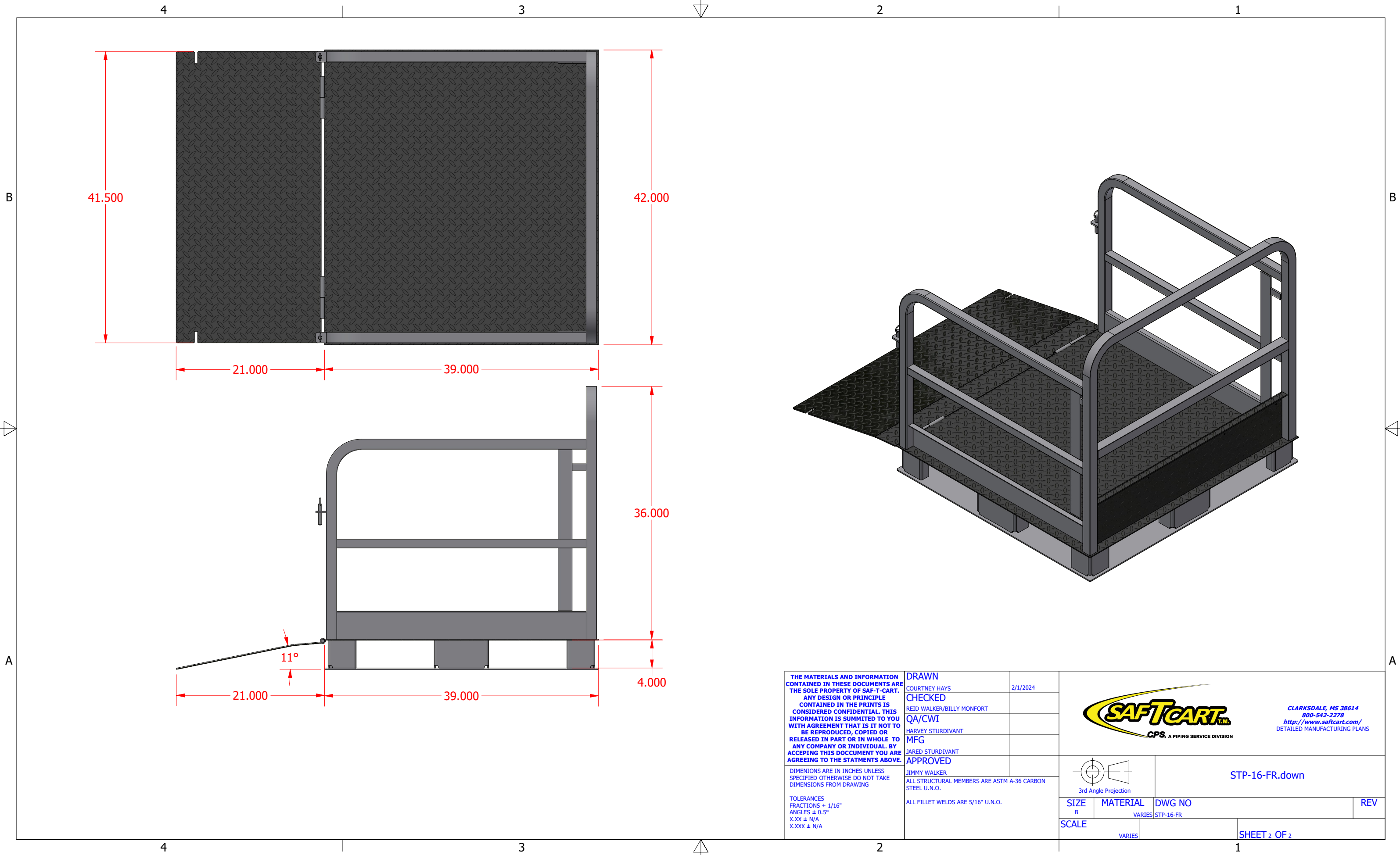

THE MATERIALS AND INFORMATION CONTAINED IN THESE DOCUMENTS ARE THE SOLE PROPERTY OF SAF-T-CART. ANY DESIGN OR PRINCIPLE CONTAINED IN THE PRINTS IS CONSIDERED CONFIDENTIAL. THIS INFORMATION IS SUMMITTED TO YOU WITH AGREEMENT THAT IS IT NOT TO BE REPRODUCED, COPIED OR RELEASED IN PART OR IN WHOLE TO ANY COMPANY OR INDIVIDUAL. BY ACCEPTING THIS DOCUMENT YOU ARE AGREEING TO THE STATEMENTS ABOVE.

DIMENSIONS ARE IN INCHES UNLESS SPECIFIED OTHERWISE DO NOT TAKE DIMENSIONS FROM DRAWING

TOLERANCES
 FRACTIONS ± 1/16"
 ANGLES ± 0.5°
 X.XX ± N/A
 X.XXX ± N/A

DRAWN
 COURTNEY HAYS 2/1/2024
CHECKED
 REID WALKER/BILLY MONFORT
QA/CWI
 HARVEY STURDIVANT
MFG
 JARED STURDIVANT
APPROVED
 JIMMY WALKER
 ALL STRUCTURAL MEMBERS ARE ASTM A-36 CARBON STEEL U.N.O.
 ALL FILLET WELDS ARE 5/16" U.N.O.



CLARKSDALE, MS 38614
 800-542-2278
<http://www.saftcart.com/>
 DETAILED MANUFACTURING PLANS

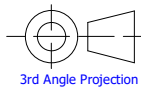

3rd Angle Projection

STP-16-FR.down

SIZE B	MATERIAL VARIES	DWG NO STP-16-FR	REV
SCALE VARIES	SHEET 2 OF 2		