

THE MATERIALS AND INFORMATION CONTAINED IN THESE DOCUMENTS ARE THE SOLE PROPERTY OF SAF-T-CART. ANY DESIGN OR PRINCIPLE CONTAINED IN THE PRINTS IS CONSIDERED CONFIDENTIAL. THIS INFORMATION IS SUMMITTED TO YOU WITH AGREEMENT THAT IS IT NOT TO BE REPRODUCED, COPIED OR RELEASED IN PART OR IN WHOLE TO ANY COMPANY OR INDIVIDUAL. BY ACCEPTING THIS DOCUMENT YOU ARE AGREEING TO THE STATEMENTS ABOVE.

DIMENSIONS ARE IN INCHES UNLESS SPECIFIED OTHERWISE DO NOT TAKE DIMENSIONS FROM DRAWING

TOLERANCES
 FRACTIONS ± 1/16"
 ANGLES ± 0.5°
 X.XX ± N/A
 X.XXX ± N/A

DRAWN	Cortney	6/11/2019
CHECKED	REID WALKER/BILLY MONFORT	
QA/CWI	HARVEY STURDIVANT	
MFG	JAMES JACO	
APPROVED	JIMMY WALKER	
ALL STRUCTURAL MEMBERS ARE ASTM A-36 CARBON STEEL U.N.O. BASED ON ASME Y14.36M-1989		
ALL FILLET WELDS ARE 5/16" U.N.O.		



AC-54-TD

SIZE	MATERIAL	DWG NO	REV
B	VARIES	AC-54-TD.drawing	
SCALE	VARIES		SHEET 1 OF 9

AC-54-L SIDE PANNEL
14GA SHEET (LASER/SAFAN)

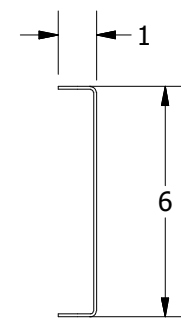
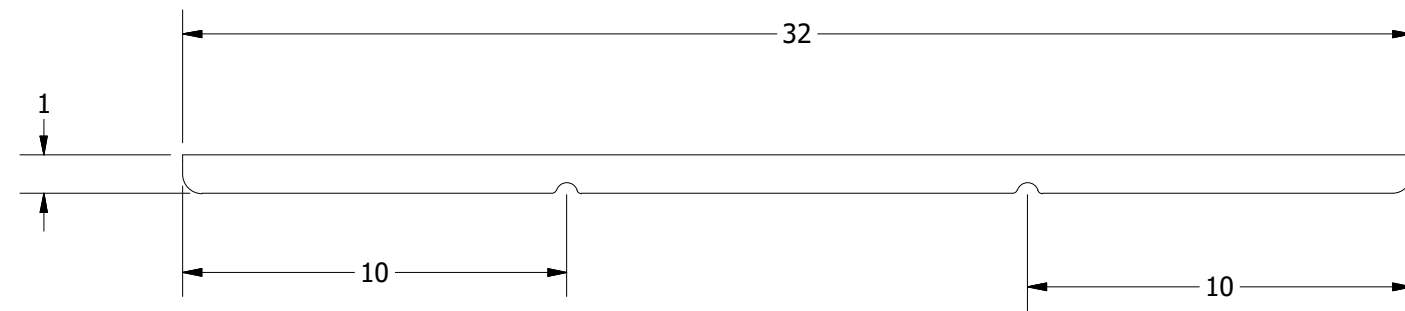
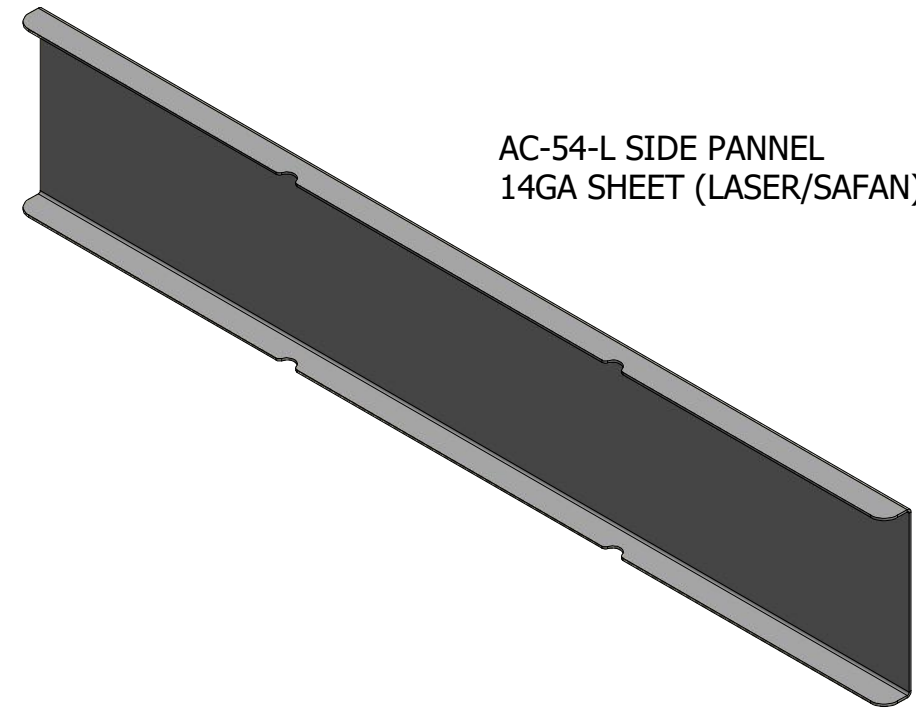

THE MATERIALS AND INFORMATION CONTAINED IN THESE DOCUMENTS ARE THE SOLE PROPERTY OF SAF-T-CART. ANY DESIGN OR PRINCIPLE CONTAINED IN THE PRINTS IS CONSIDERED CONFIDENTIAL. THIS INFORMATION IS SUMMITTED TO YOU WITH AGREEMENT THAT IS IT NOT TO BE REPRODUCED, COPIED OR RELEASED IN PART OR IN WHOLE TO ANY COMPANY OR INDIVIDUAL. BY ACCEPTING THIS DOCUMENT YOU ARE AGREEING TO THE STATEMENTS ABOVE.

DIMENSIONS ARE IN INCHES UNLESS SPECIFIED OTHERWISE DO NOT TAKE DIMENSIONS FROM DRAWING

TOLERANCES
FRACTIONS ± 1/16"
ANGLES ± 0.5°
X.XX ± N/A
X.XXX ± N/A

DRAWN Cortney	6/11/2019
CHECKED REID WALKER/BILLY MONFORT	
QA/CWI HARVEY STURDIVANT	
MFG JAMES JACO	
APPROVED JIMMY WALKER	
ALL STRUCTURAL MEMBERS ARE ASTM A-36 CARBON STEEL U.N.O. BASED ON ASME Y14.36M-1989	
ALL FILLET WELDS ARE 5/16" U.N.O.	

CLARKSDALE, MS 38614
800-542-2278
<http://www.saftcart.com/>
DETAILED MANUFACTURING PLANS

Z11210048			
SIZE B	MATERIAL VARIES	DWG NO AC-54-TD.drawing	REV
SCALE VARIES	SHEET 2 OF 9		

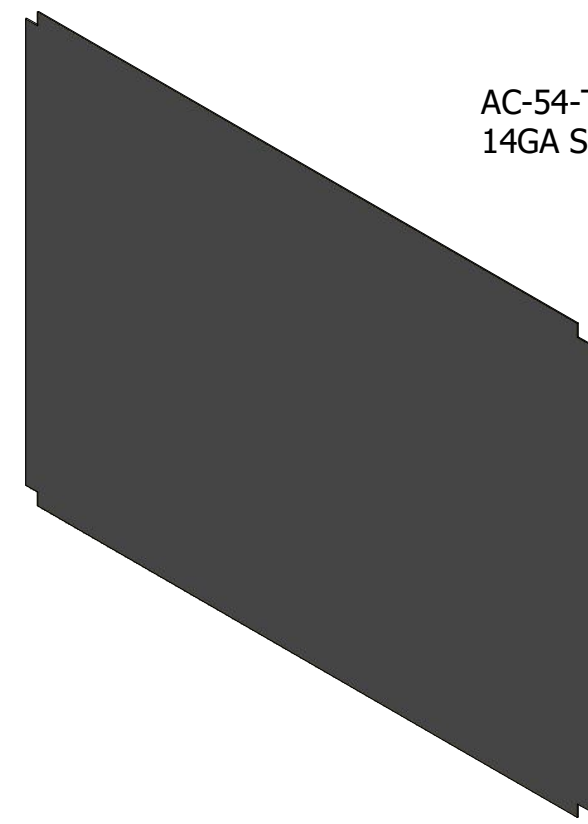
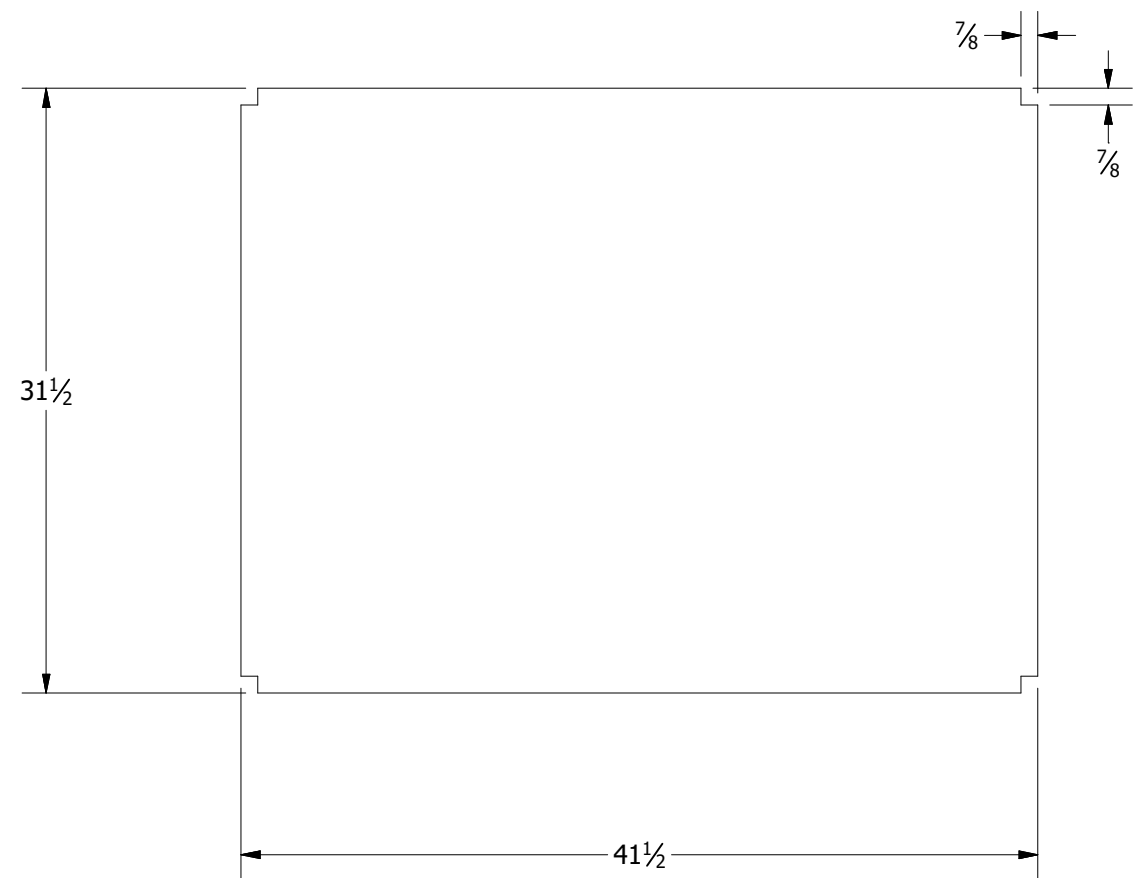

AC-54-TD TOP
14GA SHEET (LASER)

<p>THE MATERIALS AND INFORMATION CONTAINED IN THESE DOCUMENTS ARE THE SOLE PROPERTY OF SAF-T-CART. ANY DESIGN OR PRINCIPLE CONTAINED IN THE PRINTS IS CONSIDERED CONFIDENTIAL. THIS INFORMATION IS SUMMITTED TO YOU WITH AGREEMENT THAT IS IT NOT TO BE REPRODUCED, COPIED OR RELEASED IN PART OR IN WHOLE TO ANY COMPANY OR INDIVIDUAL. BY ACCEPTING THIS DOCUMENT YOU ARE AGREEING TO THE STATEMENTS ABOVE.</p> <p>DIMENSIONS ARE IN INCHES UNLESS SPECIFIED OTHERWISE DO NOT TAKE DIMENSIONS FROM DRAWING</p> <p>TOLERANCES FRACTIONS ± 1/16" ANGLES ± 0.5° X.XX ± N/A X.XXX ± N/A</p>	DRAWN	6/11/2019
	CHECKED	
	QA/CWI	
	APPROVED	
	<p>JIMMY WALKER ALL STRUCTURAL MEMBERS ARE ASTM A-36 CARBON STEEL U.N.O. BASED ON ASME Y14.36M-1989</p> <p>ALL FILLET WELDS ARE 5/16" U.N.O.</p>	



CLARKSDALE, MS 38614
800-542-2278
<http://www.saftcart.com/>
DETAILED MANUFACTURING PLANS

Z11210051			
SIZE	MATERIAL	DWG NO	REV
B	VARIES	AC-54-TD.drawing	
SCALE	VARIES		SHEET 3 OF 9

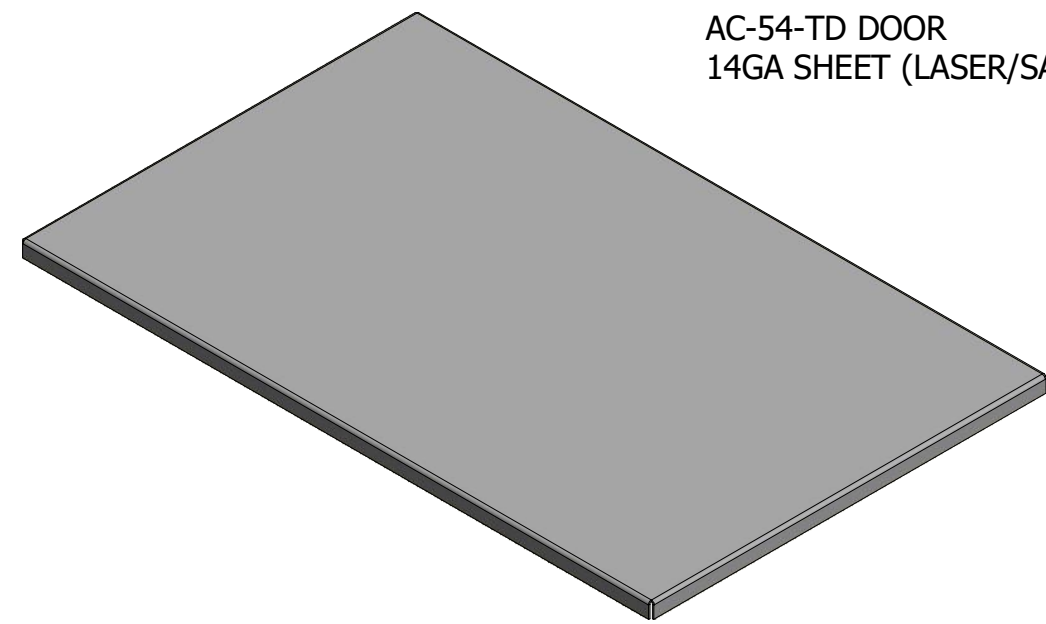
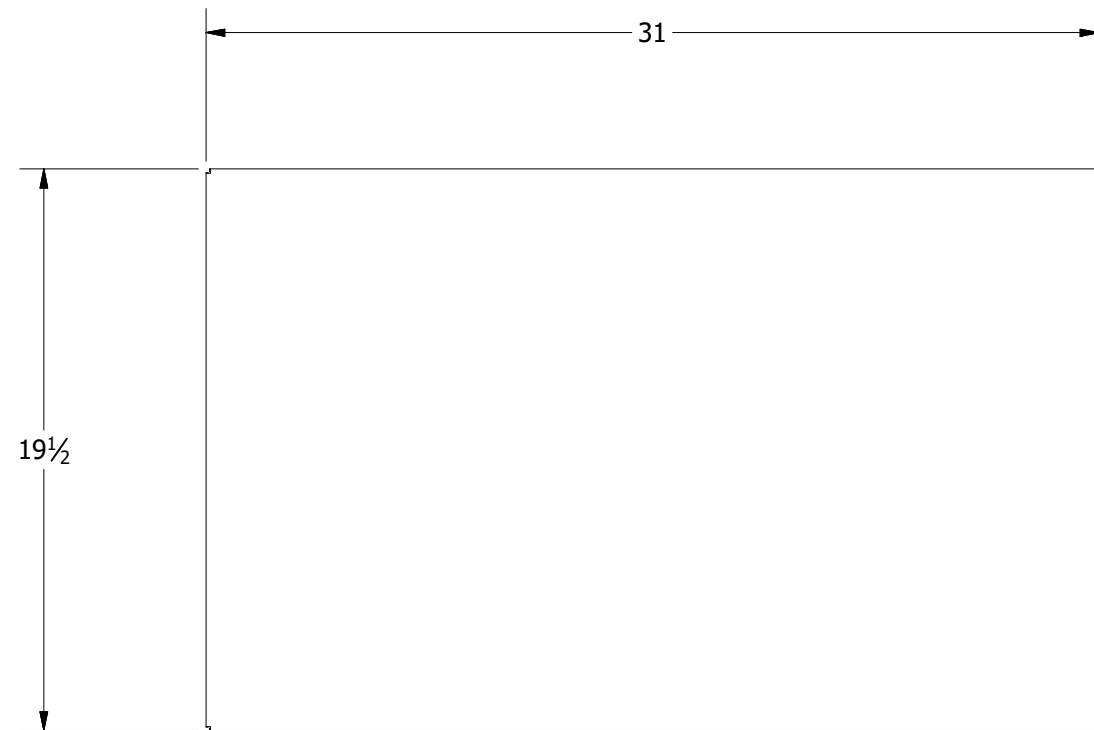

AC-54-TD DOOR
14GA SHEET (LASER/SAFAN)

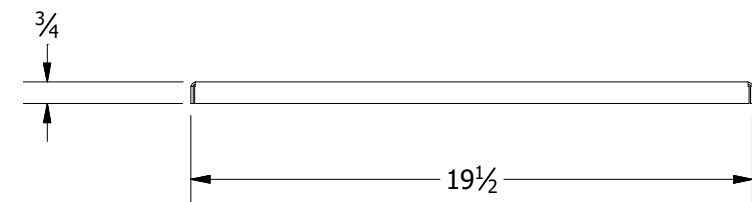
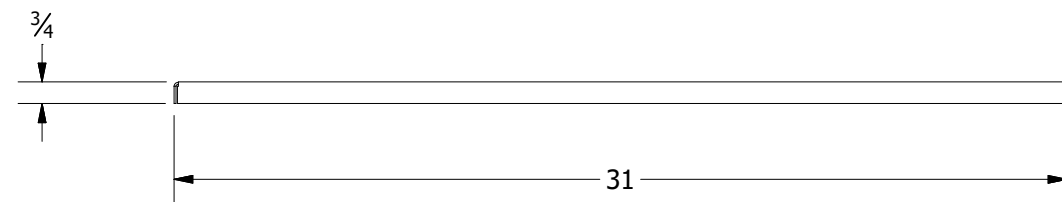

<p>THE MATERIALS AND INFORMATION CONTAINED IN THESE DOCUMENTS ARE THE SOLE PROPERTY OF SAF-T-CART. ANY DESIGN OR PRINCIPLE CONTAINED IN THE PRINTS IS CONSIDERED CONFIDENTIAL. THIS INFORMATION IS SUMMITTED TO YOU WITH AGREEMENT THAT IS IT NOT TO BE REPRODUCED, COPIED OR RELEASED IN PART OR IN WHOLE TO ANY COMPANY OR INDIVIDUAL. BY ACCEPTING THIS DOCUMENT YOU ARE AGREEING TO THE STATEMENTS ABOVE.</p> <p>DIMENSIONS ARE IN INCHES UNLESS SPECIFIED OTHERWISE DO NOT TAKE DIMENSIONS FROM DRAWING</p> <p>TOLERANCES FRACTIONS ± 1/16" ANGLES ± 0.5° X.XX ± N/A X.XXX ± N/A</p>	DRAWN	6/11/2019
	CHECKED	
	QA/CWI	
	APPROVED	
	<p>JIMMY WALKER ALL STRUCTURAL MEMBERS ARE ASTM A-36 CARBON STEEL U.N.O. BASED ON ASME Y14.36M-1989</p> <p>ALL FILLET WELDS ARE 5/16" U.N.O.</p>	



CLARKSDALE, MS 38614
800-542-2278
<http://www.saftcart.com/>
DETAILED MANUFACTURING PLANS

Z11210052

SIZE	MATERIAL	DWG NO	REV
B	VARIES	AC-54-TD.drawing	
SCALE	VARIES		SHEET 4 OF 9

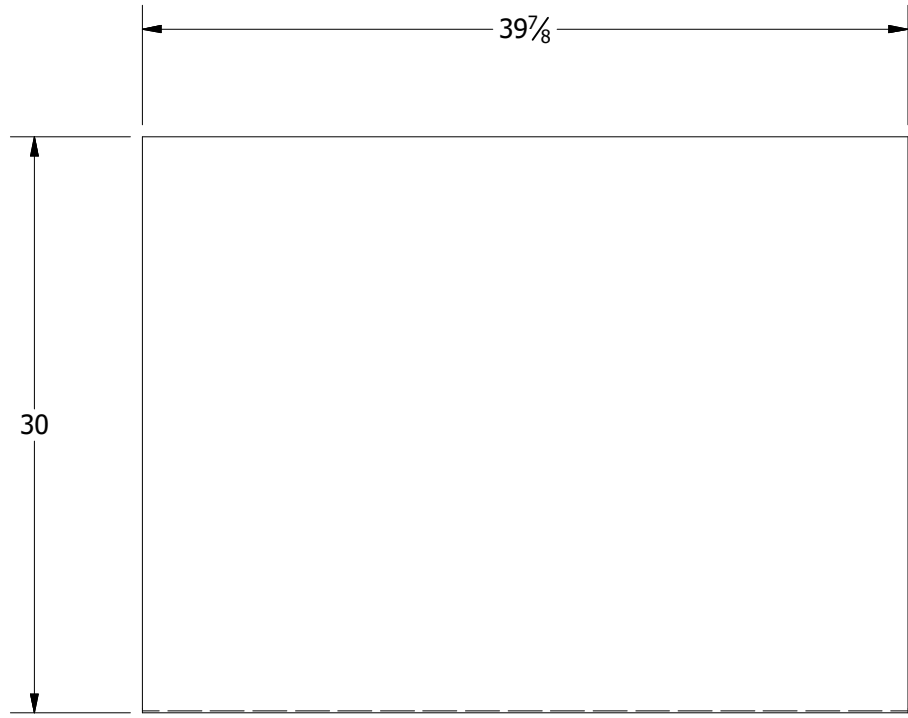

AC-54 (MOST MODELS) FLOOR PLATE
12GA SHEET (LASER/SAFAN)

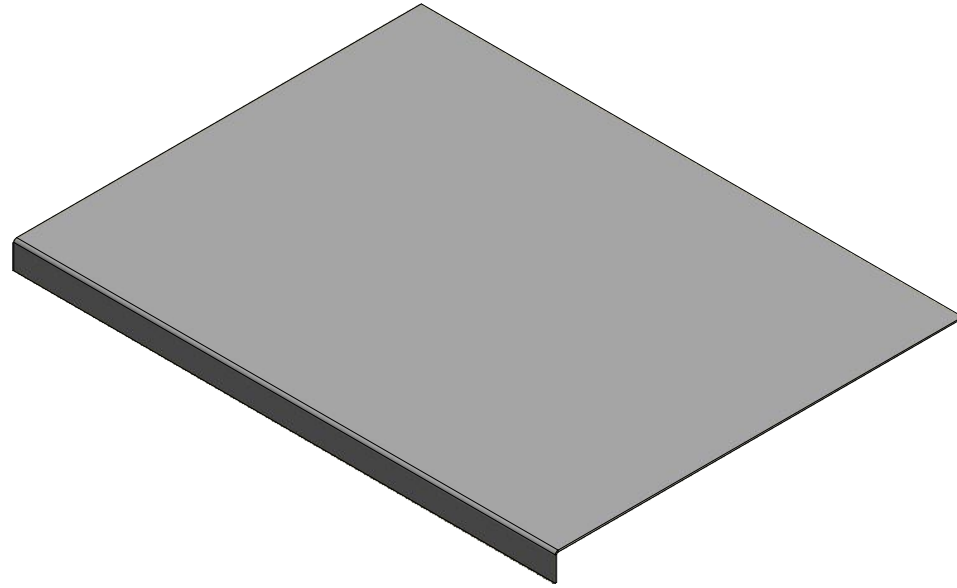

FLAT PATTERN FOR (SHEAR/BEND)

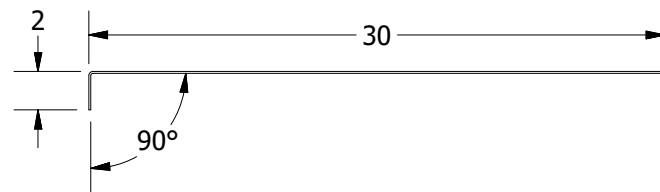
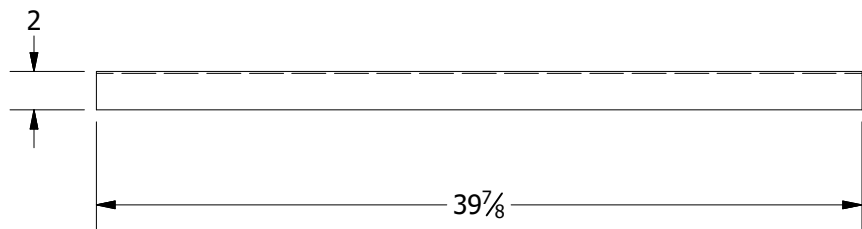
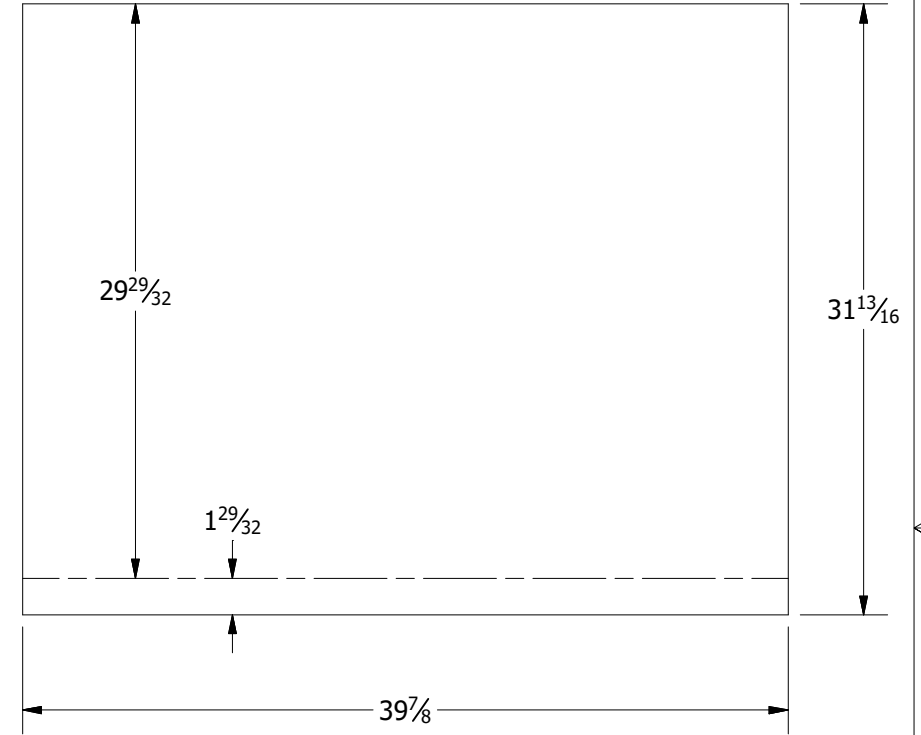

THE MATERIALS AND INFORMATION CONTAINED IN THESE DOCUMENTS ARE THE SOLE PROPERTY OF SAF-T-CART. ANY DESIGN OR PRINCIPLE CONTAINED IN THE PRINTS IS CONSIDERED CONFIDENTIAL. THIS INFORMATION IS SUMMITTED TO YOU WITH AGREEMENT THAT IS IT NOT TO BE REPRODUCED, COPIED OR RELEASED IN PART OR IN WHOLE TO ANY COMPANY OR INDIVIDUAL. BY ACCEPTING THIS DOCUMENT YOU ARE AGREEING TO THE STATEMENTS ABOVE.

DIMENSIONS ARE IN INCHES UNLESS SPECIFIED OTHERWISE DO NOT TAKE DIMENSIONS FROM DRAWING

TOLERANCES
FRACTIONS ± 1/16"
ANGLES ± 0.5°
X.XX ± N/A
X.XXX ± N/A

DRAWN	Cortney	6/11/2019
CHECKED	REID WALKER/BILLY MONFORT	
QA/CWI	HARVEY STURDIVANT	
MFG	JAMES JACO	
APPROVED	JIMMY WALKER	
ALL STRUCTURAL MEMBERS ARE ASTM A-36 CARBON STEEL U.N.O. BASED ON ASME Y14.36M-1989		
ALL FILLET WELDS ARE 5/16" U.N.O.		

CLARKSDALE, MS 38614
800-542-2278
<http://www.saftcart.com/>
DETAILED MANUFACTURING PLANS

Z11310026

SIZE	MATERIAL	DWG NO	REV
B	VARIES	AC-54-TD.drawing	
SCALE	VARIES	SHEET 5 OF 9	

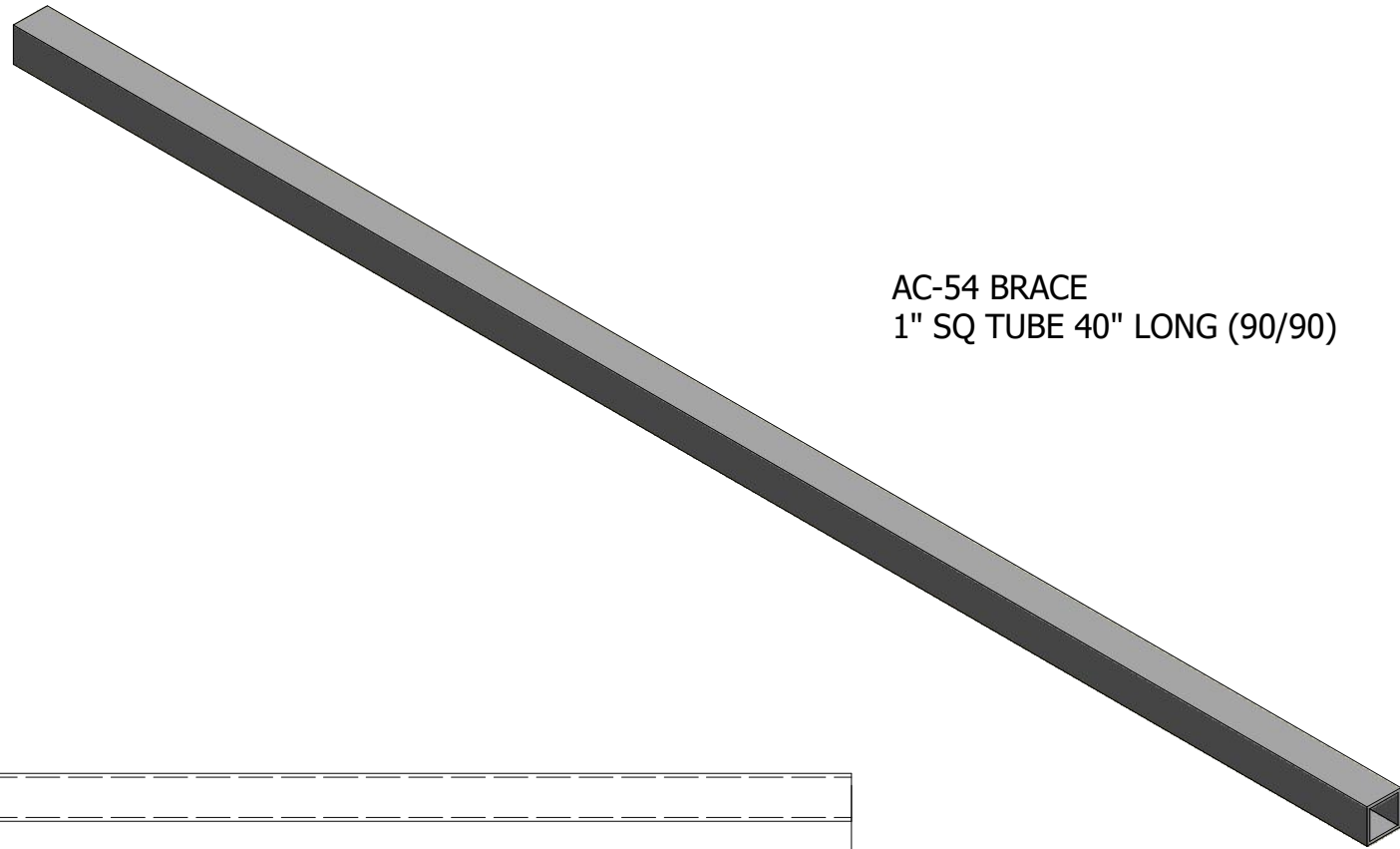

AC-54 BRACE
1" SQ TUBE 40" LONG (90/90)

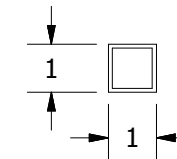
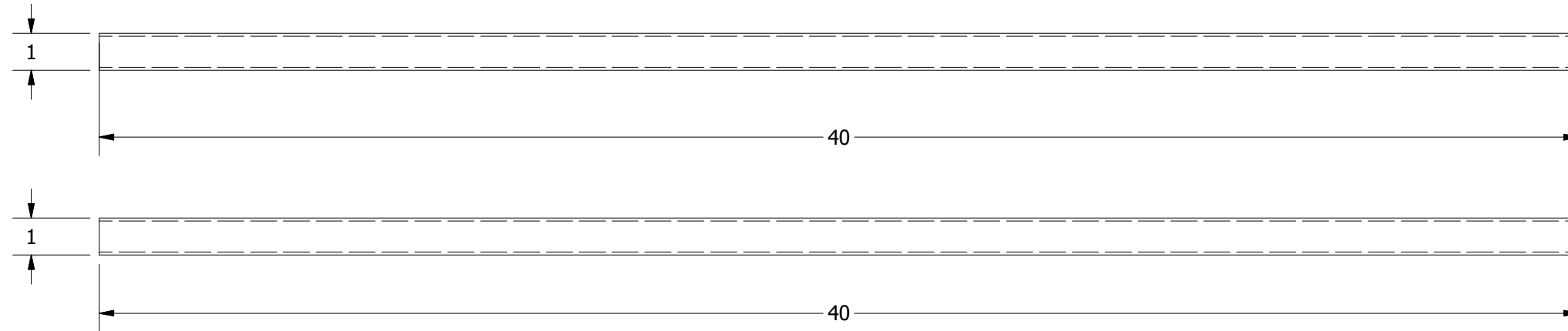

THE MATERIALS AND INFORMATION CONTAINED IN THESE DOCUMENTS ARE THE SOLE PROPERTY OF SAF-T-CART. ANY DESIGN OR PRINCIPLE CONTAINED IN THE PRINTS IS CONSIDERED CONFIDENTIAL. THIS INFORMATION IS SUMMITTED TO YOU WITH AGREEMENT THAT IS IT NOT TO BE REPRODUCED, COPIED OR RELEASED IN PART OR IN WHOLE TO ANY COMPANY OR INDIVIDUAL. BY ACCEPTING THIS DOCUMENT YOU ARE AGREEING TO THE STATEMENTS ABOVE.

DIMENSIONS ARE IN INCHES UNLESS SPECIFIED OTHERWISE DO NOT TAKE DIMENSIONS FROM DRAWING

TOLERANCES
FRACTIONS $\pm 1/16"$
ANGLES $\pm 0.5^\circ$
X.XX $\pm N/A$
X.XXX $\pm N/A$

DRAWN

Cortney 6/11/2019

CHECKED

REID WALKER/BILLY MONFORT

QA/CWI

HARVEY STURDIVANT

MFG

JAMES JACO

APPROVED

JIMMY WALKER

ALL STRUCTURAL MEMBERS ARE ASTM A-36 CARBON STEEL U.N.O. BASED ON ASME Y14.36M-1989

ALL FILLET WELDS ARE 5/16" U.N.O.



CLARKSDALE, MS 38614
800-542-2278
<http://www.saftcart.com/>
DETAILED MANUFACTURING PLANS

Z41210014

SIZE	MATERIAL	DWG NO	REV
B	VARIES	AC-54-TD.drawing	
SCALE	VARIES	SHEET 6 OF 9	

AC-54 BRACE
1" SQ TUBE 30" LONG (90/90)

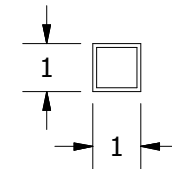
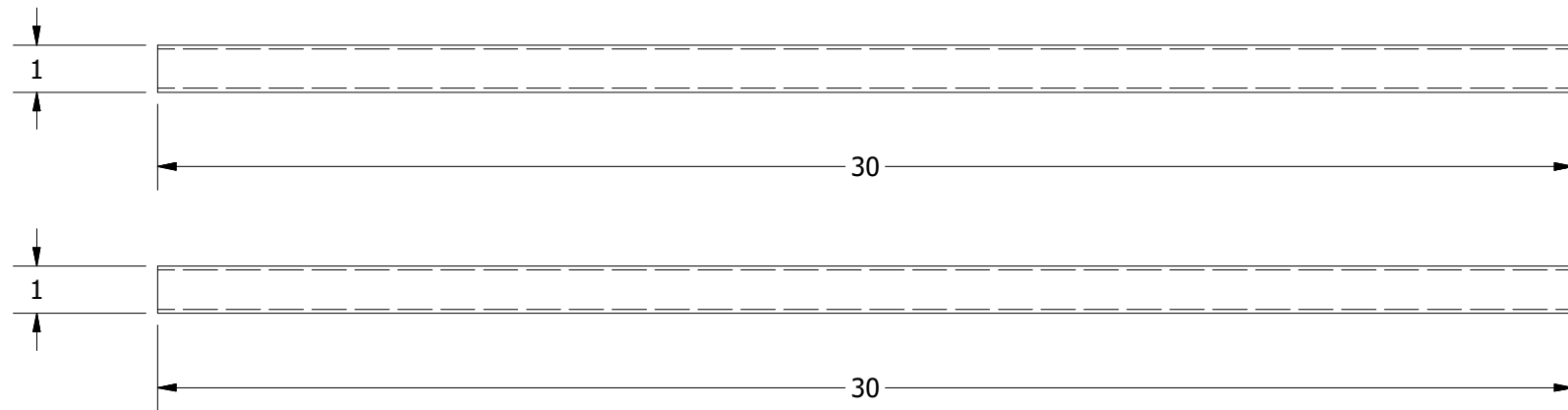
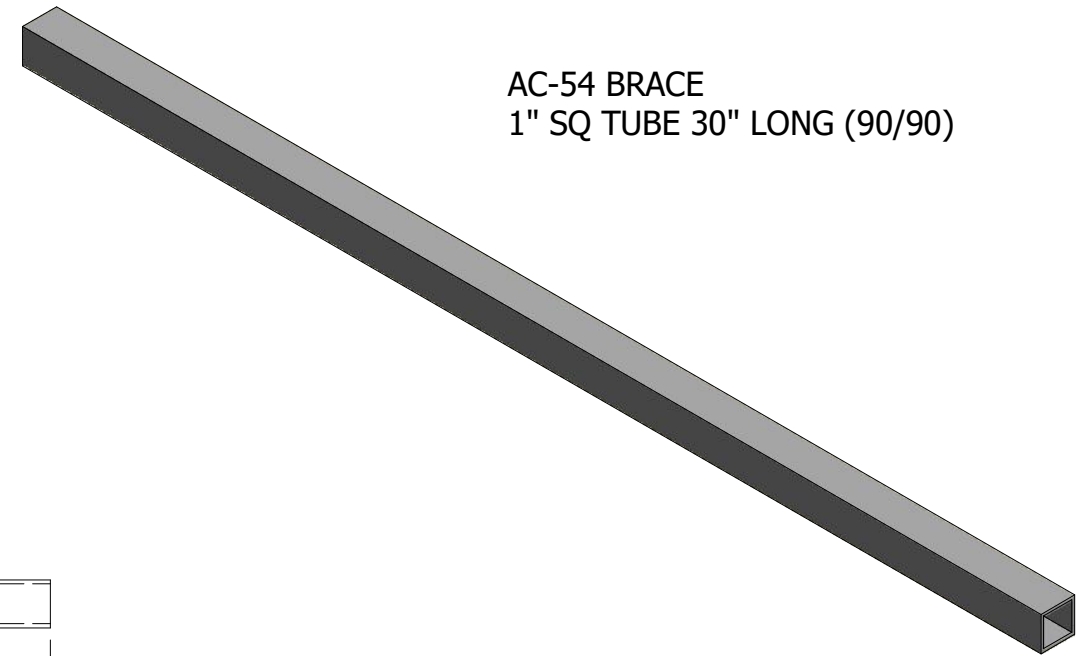

THE MATERIALS AND INFORMATION CONTAINED IN THESE DOCUMENTS ARE THE SOLE PROPERTY OF SAF-T-CART. ANY DESIGN OR PRINCIPLE CONTAINED IN THE PRINTS IS CONSIDERED CONFIDENTIAL. THIS INFORMATION IS SUMMITTED TO YOU WITH AGREEMENT THAT IS IT NOT TO BE REPRODUCED, COPIED OR RELEASED IN PART OR IN WHOLE TO ANY COMPANY OR INDIVIDUAL. BY ACCEPTING THIS DOCUMENT YOU ARE AGREEING TO THE STATEMENTS ABOVE.

DIMENSIONS ARE IN INCHES UNLESS SPECIFIED OTHERWISE DO NOT TAKE DIMENSIONS FROM DRAWING

TOLERANCES
FRACTIONS $\pm 1/16"$
ANGLES $\pm 0.5^\circ$
X.XX \pm N/A
X.XXX \pm N/A

DRAWN

Cortney

6/11/2019

CHECKED

REID WALKER/BILLY MONFORT

QA/CWI

HARVEY STURDIVANT

MFG

JAMES JACO

APPROVED

JIMMY WALKER

ALL STRUCTURAL MEMBERS ARE ASTM A-36 CARBON STEEL U.N.O. BASED ON ASME Y14.36M-1989

ALL FILLET WELDS ARE 5/16" U.N.O.



CLARKSDALE, MS 38614
800-542-2278
<http://www.saftcart.com/>
DETAILED MANUFACTURING PLANS

Z41210015

SIZE	MATERIAL	DWG NO	REV
B	VARIES	AC-54-TD.drawing	
SCALE	VARIES	SHEET 7 OF 9	

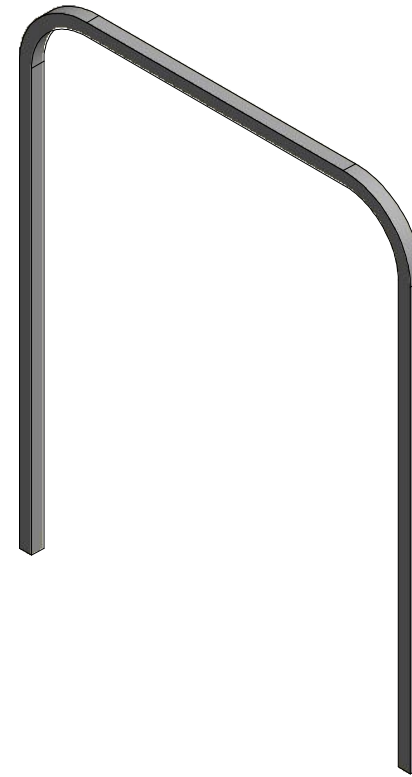
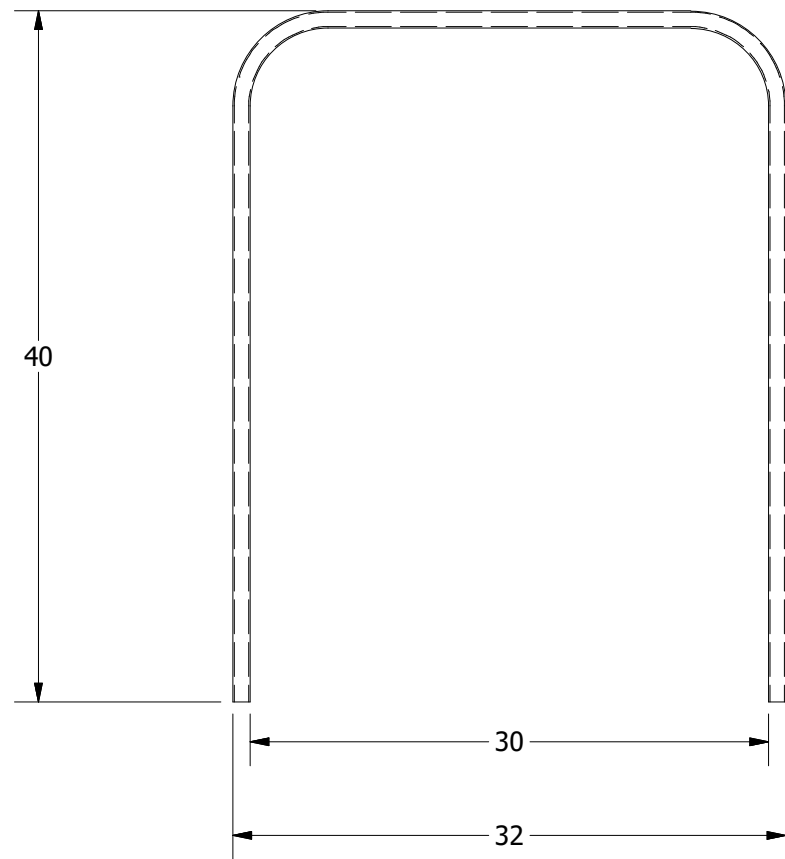

AC-54-L FRAME
 1" SQ TUBE 107" BEFORE BEND(90/90)
 (SAW/BEND)

THE MATERIALS AND INFORMATION CONTAINED IN THESE DOCUMENTS ARE THE SOLE PROPERTY OF SAF-T-CART. ANY DESIGN OR PRINCIPLE CONTAINED IN THE PRINTS IS CONSIDERED CONFIDENTIAL. THIS INFORMATION IS SUMMITTED TO YOU WITH AGREEMENT THAT IS IT NOT TO BE REPRODUCED, COPIED OR RELEASED IN PART OR IN WHOLE TO ANY COMPANY OR INDIVIDUAL. BY ACCEPTING THIS DOCUMENT YOU ARE AGREEING TO THE STATMENTS ABOVE.

DIMENSIONS ARE IN INCHES UNLESS SPECIFIED OTHERWISE DO NOT TAKE DIMENSIONS FROM DRAWING

TOLERANCES
 FRACTIONS ± 1/16"
 ANGLES ± 0.5°
 X.XX ± N/A
 X.XXX ± N/A

DRAWN Cortney	6/11/2019
CHECKED REID WALKER/BILLY MONFORT	
QA/CWI HARVEY STURDIVANT	
MFG JAMES JACO	
APPROVED JIMMY WALKER	
ALL STRUCTURAL MEMBERS ARE ASTM A-36 CARBON STEEL U.N.O. BASED ON ASME Y14.36M-1989	
ALL FILLET WELDS ARE 5/16" U.N.O.	

CLARKSDALE, MS 38614
 800-542-2278
<http://www.saftcart.com/>
 DETAILED MANUFACTURING PLANS

Z41210016

SIZE B	MATERIAL VARIES	DWG NO AC-54-TD.drawing	REV
SCALE	SHEET 8 OF 9		

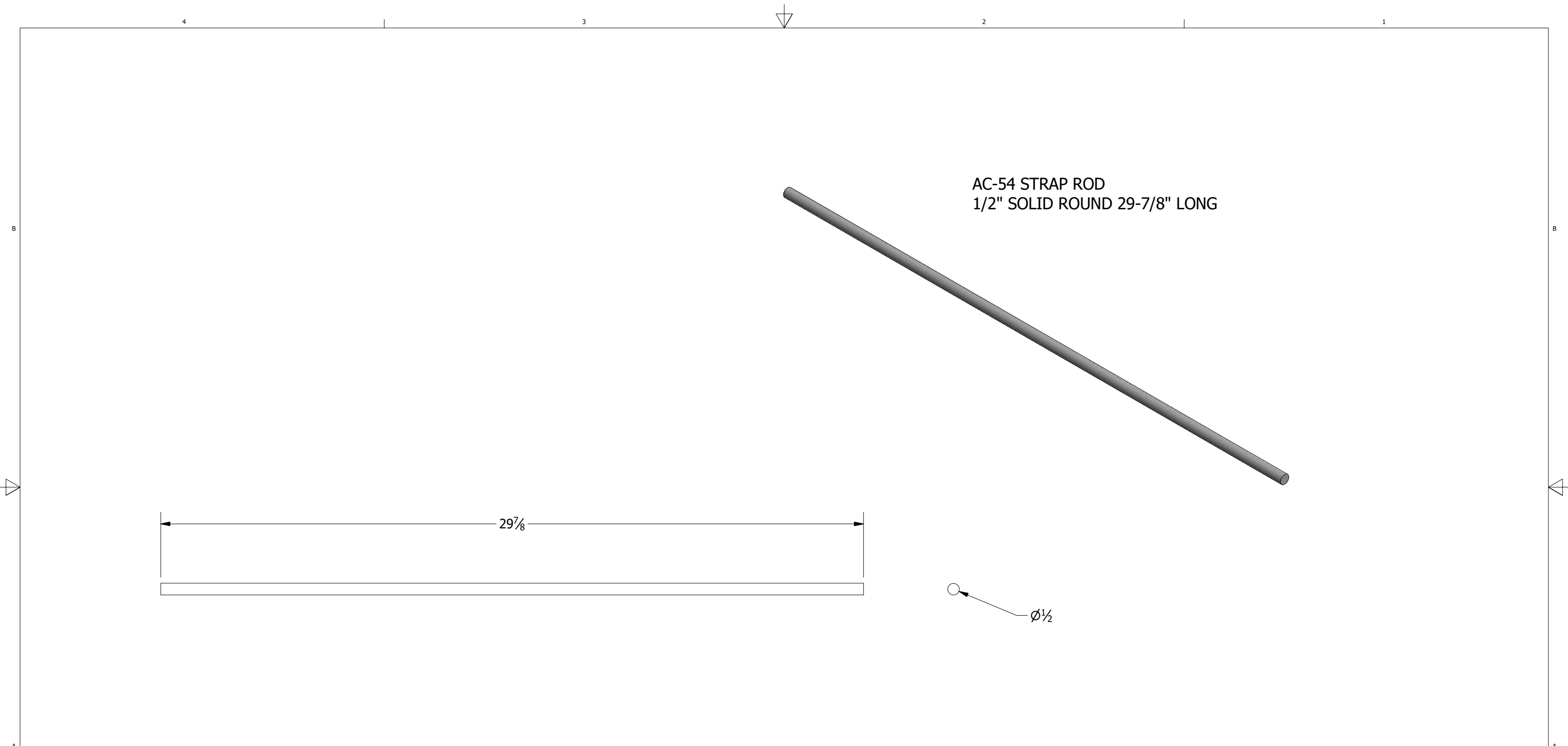

AC-54 STRAP ROD
 1/2" SOLID ROUND 29-7/8" LONG

29⁷/₈

Ø¹/₂

THE MATERIALS AND INFORMATION CONTAINED IN THESE DOCUMENTS ARE THE SOLE PROPERTY OF SAF-T-CART. ANY DESIGN OR PRINCIPLE CONTAINED IN THE PRINTS IS CONSIDERED CONFIDENTIAL. THIS INFORMATION IS SUMMITTED TO YOU WITH AGREEMENT THAT IS IT NOT TO BE REPRODUCED, COPIED OR RELEASED IN PART OR IN WHOLE TO ANY COMPANY OR INDIVIDUAL. BY ACCEPTING THIS DOCUMENT YOU ARE AGREEING TO THE STATEMENTS ABOVE.

DIMENSIONS ARE IN INCHES UNLESS SPECIFIED OTHERWISE DO NOT TAKE DIMENSIONS FROM DRAWING
 TOLERANCES
 FRACTIONS ± 1/16"
 ANGLES ± 0.5°
 X.XX ± N/A
 X.XXX ± N/A

DRAWN Cortney 6/11/2019
CHECKED REID WALKER/BILLY MONFORT
QA/CWI HARVEY STURDIVANT
MFG JAMES JACO
APPROVED JIMMY WALKER
ALL STRUCTURAL MEMBERS ARE ASTM A-36 CARBON STEEL U.N.O. BASED ON ASME Y14.36M-1989
ALL FILLET WELDS ARE 5/16" U.N.O.

SAFTCART^{T.M.}
 CLARKSDALE, MS 38614
 800-542-2278
<http://www.saftcart.com/>
 DETAILED MANUFACTURING PLANS

Z61810001

SIZE B	MATERIAL VARIES	DWG NO AC-54-TD.drawing	REV
SCALE VARIES	SHEET 9 OF 9		