

DRAWN	5/2/2023
CLAUDE CLEGG	
CHECKED	
REID WALKER	
QA/CWI	
HARVEY STURDIVANT	
MFG	
JARED STURDIVANT	
APPROVED	
JIMMY WALKER	
DIMENSIONS ARE IN INCHES UNLESS SPECIFIED OTHERWISE DO NOT TAKE DIMENSIONS FROM DRAWING	
ALL STRUCTURAL MEMBERS ARE ASTM A-36 CARBON STEEL U.N.O. BASED ON ASME Y14.36M-1989	
ALL FILLET WELDS ARE 5/16" U.N.O.	



CLARKSDALE, MS 38614  
800-542-2278  
<http://www.saftcart.com/>  
DETAILED MANUFACTURING PLANS

750-20-LIFT			
SIZE	MATERIAL	DWG NO	REV
B	VARIABLES	750-20-LIFT	
SCALE	VARIABLES		SHEET 1 OF 2

DRILL-DRIVEN  
WINCH MOUNT  
(INCLUDED, NOT PICTURED)

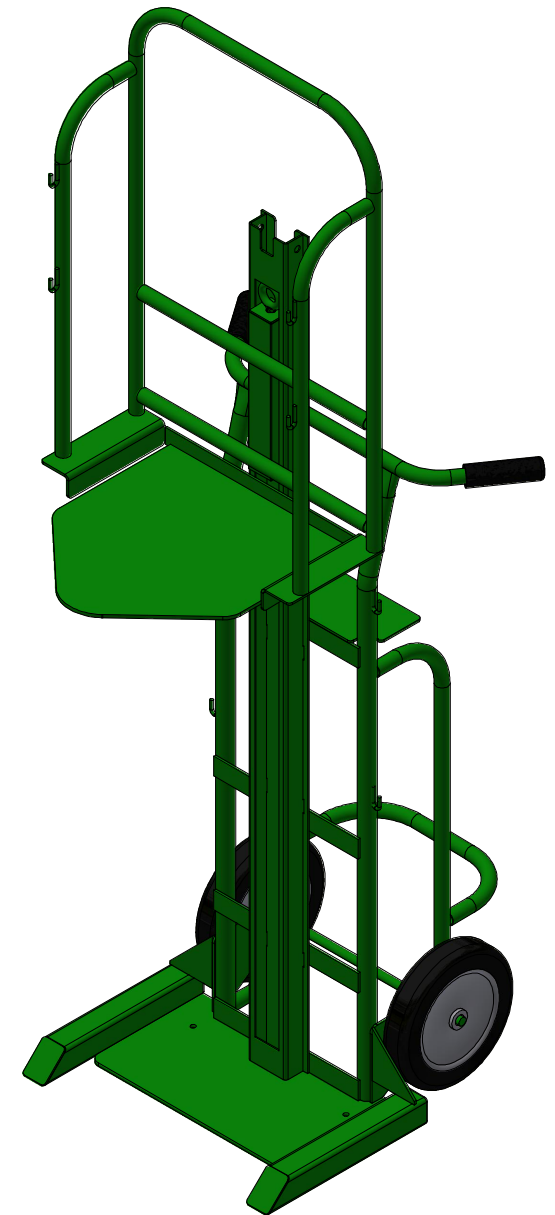
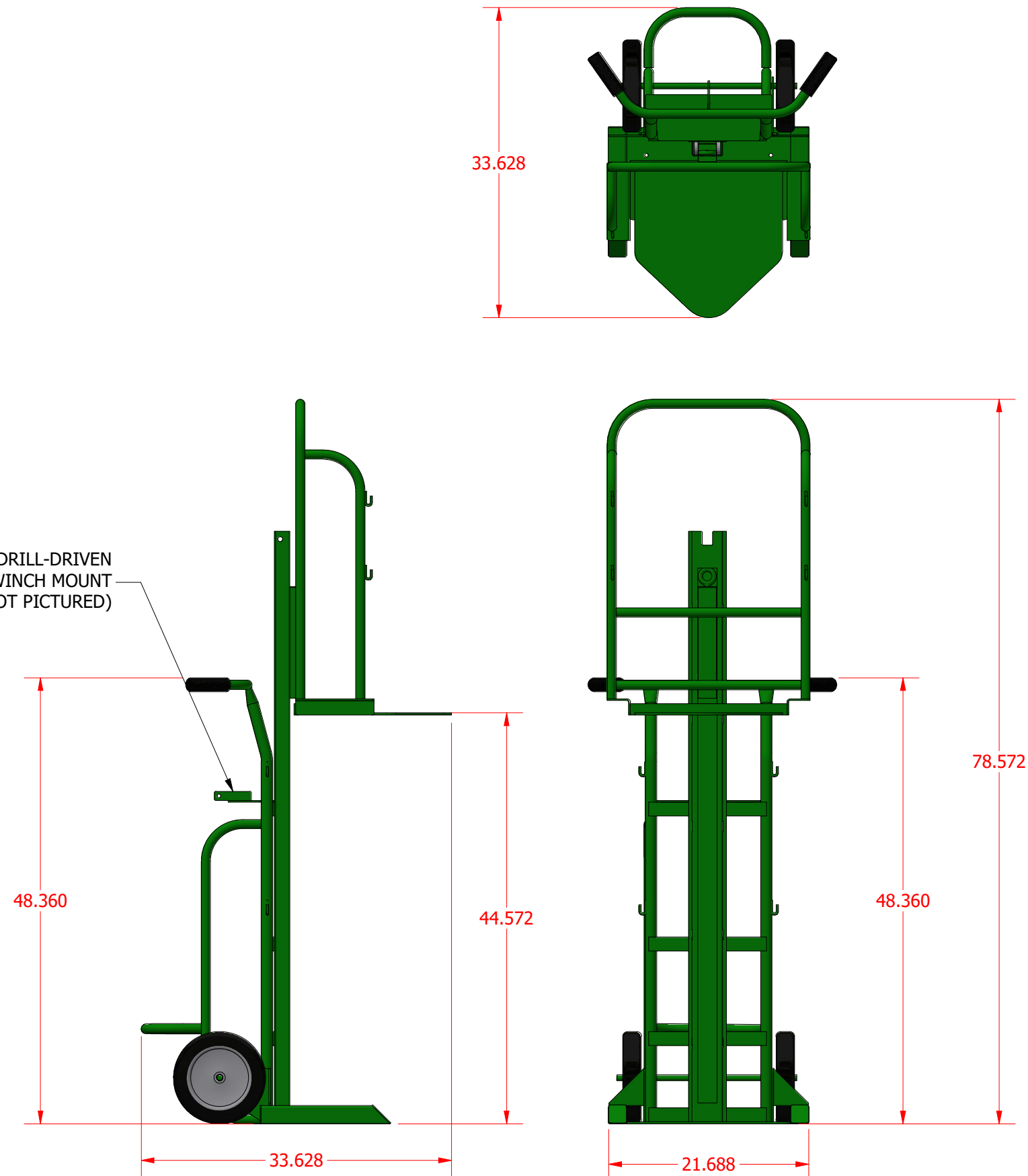

DRAWN	5/2/2023
CLAUDE CLEGG	
CHECKED	
REID WALKER	
QA/CWI	
HARVEY STURDIVANT	
MFG	
JARED STURDIVANT	
APPROVED	
JIMMY WALKER	
DIMENSIONS ARE IN INCHES UNLESS SPECIFIED OTHERWISE DO NOT TAKE DIMENSIONS FROM DRAWING	
ALL STRUCTURAL MEMBERS ARE ASTM A-36 CARBON STEEL U.N.O. BASED ON ASME Y14.36M-1989	
ALL FILLET WELDS ARE 5/16" U.N.O.	

**SAFTCART<sup>t.m.</sup>**  
CLARKSDALE, MS 38614  
 800-542-2278  
<http://www.saftcart.com/>  
 DETAILED MANUFACTURING PLANS

**750-20-LIFT**

SIZE	MATERIAL	DWG NO	REV
B	VARIES	750-20-LIFT	
SCALE	SHEET 2 OF 2		
VARIES			