

SPRING PIN ASSEMBLY

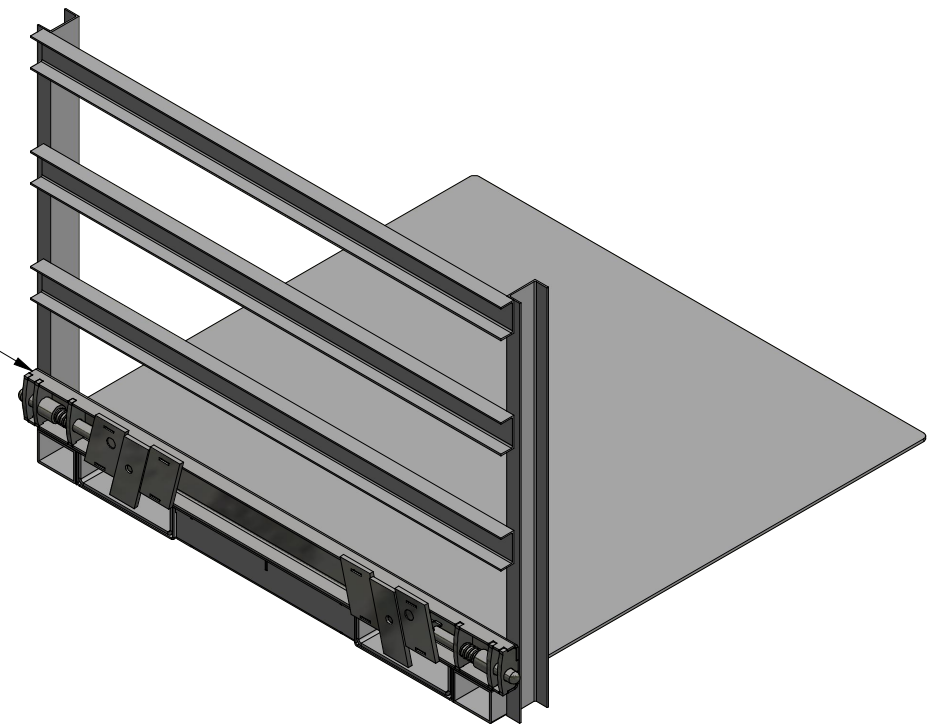

THE MATERIALS AND INFORMATION CONTAINED IN THESE DOCUMENTS ARE THE SOLE PROPERTY OF SAF-T-CART. ANY DESIGN OR PRINCIPLE CONTAINED IN THE PRINTS IS CONSIDERED CONFIDENTIAL. THIS INFORMATION IS SUMMITTED TO YOU WITH AGREEMENT THAT IS IT NOT TO BE REPRODUCED, COPIED OR RELEASED IN PART OR IN WHOLE TO ANY COMPANY OR INDIVIDUAL. BY ACCEPTING THIS DOCUMENT YOU ARE AGREEING TO THE STATEMENTS ABOVE.

DIMENSIONS ARE IN INCHES UNLESS SPECIFIED OTHERWISE DO NOT TAKE DIMENSIONS FROM DRAWING

TOLERANCES  
FRACTIONS ± 1/16"  
ANGLES ± 0.5°  
X.XX ± N/A  
X.XXX ± N/A

DRAWN	WELBY	7/16/2019
CHECKED	REID WALKER/BILLY MONFORT	
QA/CWI	HARVEY STURDIVANT	
MFG	JAMES JACO	
APPROVED	JIMMY WALKER	
ALL STRUCTURAL MEMBERS ARE ASTM A-36 CARBON STEEL U.N.O. BASED ON ASME Y14.36M-1989		
ALL FILLET WELDS ARE 5/16" U.N.O.		



CLARKSDALE, MS 38614  
800-542-2278  
<http://www.saftcart.com/>  
DETAILED MANUFACTURING PLANS

STP-16B-PIN

SIZE	MATERIAL	DWG NO	REV
B	VARIABLES	STP-16B-PIN	
SCALE	VARIABLES		SHEET 1 OF 1