

VIEW B-B  
SCALE 1/18

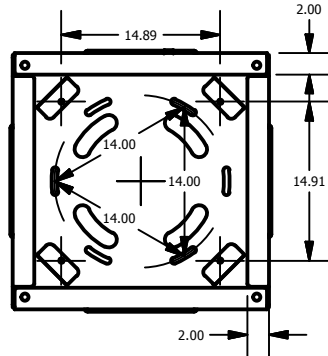

VIEW A-A  
SCALE 1/18

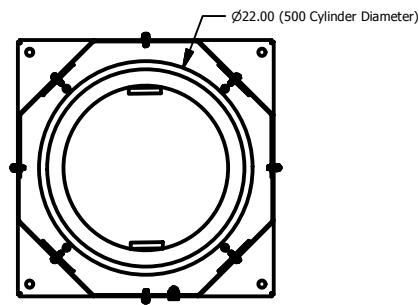
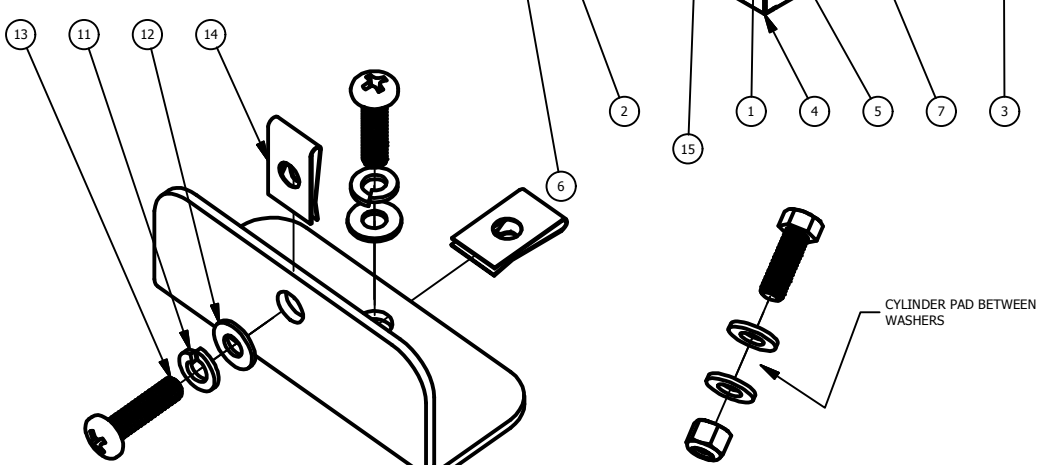
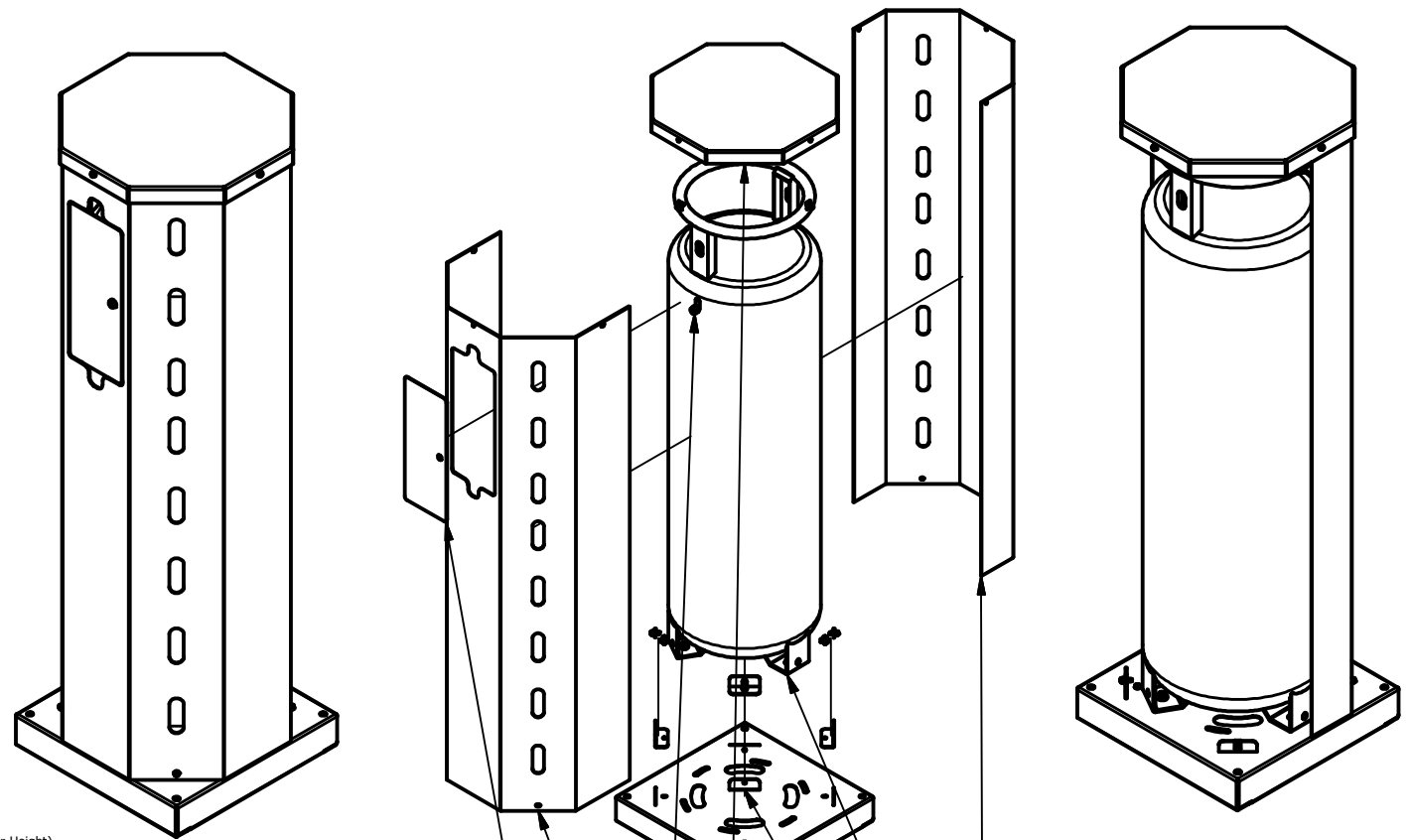

CYLINDER PAD BETWEEN WASHERS

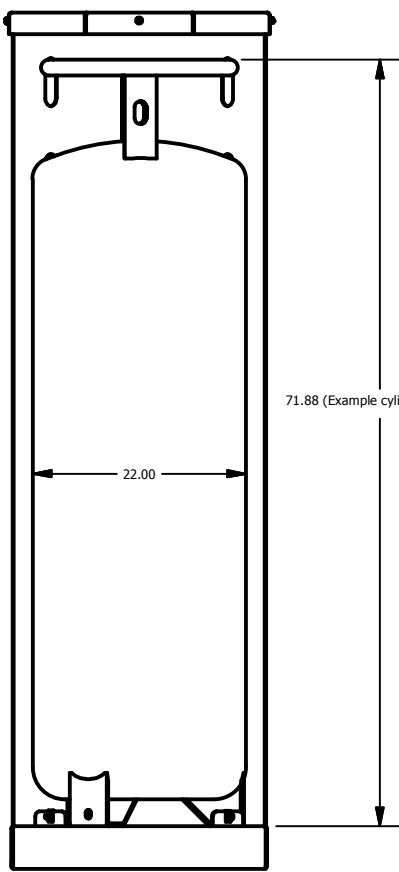
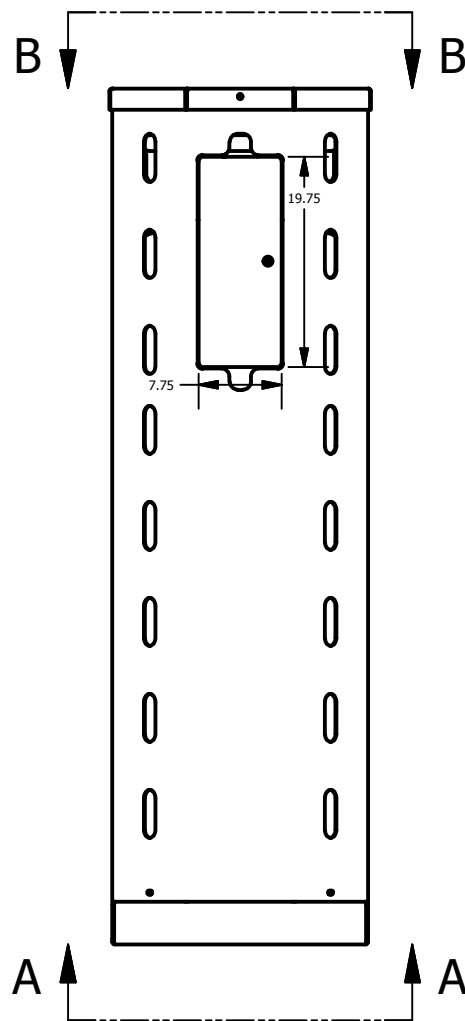
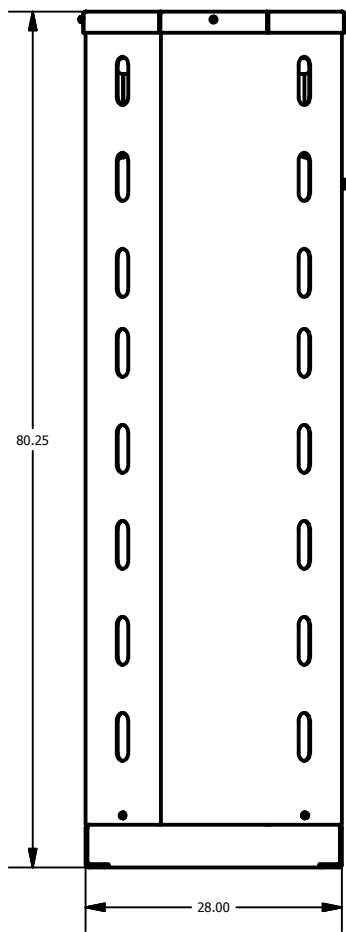

DRAWN	WELBY WU	B.S.M.F.	3-23-2016
CHECKED	COURTNEY HAYS	QA/CWI	
	HARVEY STURDIVANT	MFG	
APPROVED	JAMES JACO		
	JIMMY WALKER		
DIMENSIONS ARE IN INCHES UNLESS SPECIFIED OTHERWISE DO NOT TAKE DIMENSIONS FROM DRAWING			
ALL STRUCTURAL MEMBERS ARE ALUMINUM U.N.O. BASED ON ASME Y14.36M-1989			
ALL FILLET WELDS ARE 5/16" U.N.O.			

**SAFTCART™**  
 CLARKSDALE, MS 38614  
 800-542-2278  
<http://www.saftcart.com/>  
 DETAILED MANUFACTURING PLANS

CM-500			
SIZE	MATERIAL	DWG NO	REV
B	VARIES	CM-500	1
SCALE	SHEET 1 OF 1		
VARIES			